

## ROTARY STONE HEART DOUBLE BURNER GAS OVEN

### RANGE FGR



- Rotary stone hearth gas pizza oven with double burner and thermostatic heating system with digital safety controls independent between crown and bedplate, it's available in 3 sizes.
- The bedplate rotation is applied through an inverter equipped with a full programmable baking system.
- Strong thermal flywheel oven effect combined with the rotary bedplate system gives to the oven an excellent homogeneity and best baking quality.
- The double burner gas heating system with ash drawer allows this oven of the best and healthful pizza backing performances.
- "FGR" ovens are equipped with our exclusive maintenance free atmospheric infrared gas burners, they can operate with Natural Gas or LPG.
- Thermal insulation is made of mineral fibre with high insulating properties.
- Dome structure on refractory material is guaranteed 10 years.

#### Electrical connections:

3 phases 400V – Single phase 230V 50/60Hz.

Ovens manufactured in compliance with EEC Directive 90/396 of Jun 29,1990

Ref./ Mod	Capacity pizzas Ø 30 cm.	Productivity per hour	Tabel Gas Burner Oven Range "FGR"					
			Oven Mod.	Weight (kg)	Total Gas Potential	Consumption	Gas Fittings	
					Methane (mc/h)	G.P.L./L.P.G. (Kg/h)		
FGR110	7 pizze	120 pizze/h	FGR110	1400	28 kW	2,9	2,1	3/4" G
FGR130	10 pizze	170 pizze/h	FGR130	1650	36 kW	3,8	2,7	3/4" G
FGR150	14 pizze	240 pizze/h	FGR150	2150	43 kW	5	3,3	3/4" G



# Morello Forni



ROTARY STONE HEART DOUBLE BURNER GAS OVEN  
FORNO ROTATIVO A GAS CON DOPPIO BRUCIATORE



[www.morelloforni.com](http://www.morelloforni.com)

**FGR**  
RANGE  
SERIE

## FORNI ROTATIVI A GAS SERIE "FGR"

- Forno rotativo per pizza a gas con sistema di riscaldamento termostatico a doppio bruciatore con controllo digitale indipendente tra cielo e platea, disponibile in 3 misure.
- La rotazione della platea è gestita tramite un inverter dotato di sistema programmabile.
- Forno dotato di eccellente omogeneità ed alta qualità di cottura grazie all'azione combinata del piano rotante e del suo forte effetto volano termico.
- Il sistema a doppio bruciatore con cassetto di caduta e raccolta ceneri, garantisce grandi capacità produttive e la migliore igiene.
- I forni "FGR" sono equipaggiati con i nostri esclusivi bruciatori atmosferici esenti da manutenzione e possono funzionare con gas metano o GPL.
- Isolamento termico realizzato in fibra minerale ad alto potere isolante
- Struttura in resistentissimo materiale refrattario garantito 10 anni.

### Collegamento elettrico:

trifase 400V – monofase 230V 50/60Hz

Forni costruiti in conformità con la direttiva CEE 90/396 del 29-06-1990

## ROTARY STONE HEARTH GAS OVEN RANGE "FGR"

- Rotary stone hearth gas pizza oven with double burner and thermostatic heating system with digital safety controls independent between crown and bedplate, it's available in 3 sizes.
- The bedplate rotation is applied through an inverter equipped with a full programmable baking system.
- Strong thermal flywheel oven effect combined with the rotary bedplate system gives to the oven an excellent homogeneity and best baking quality.
- The double burner gas heating system with ash drawer allows this oven of the best and healthful pizza backing performances.
- "FGR" ovens are equipped with our exclusive maintenance free atmospheric infrared gas burners, they can operate with Natural Gas or LPG.
- Thermal insulation is made of mineral fibre with high insulating properties.
- Dome structure on refractory material is guaranteed 10 years.

### Electrical connections:

3 phases 400V – Single phase 230V 50/60Hz.

Ovens manufactured in compliance with EEC Directive 90/396 of Jun 29,1990

# FGR RANGE SERIE



**DOUBLE GAS BURNER  
GAS CON  
DOPPIO BRUCIATORE**

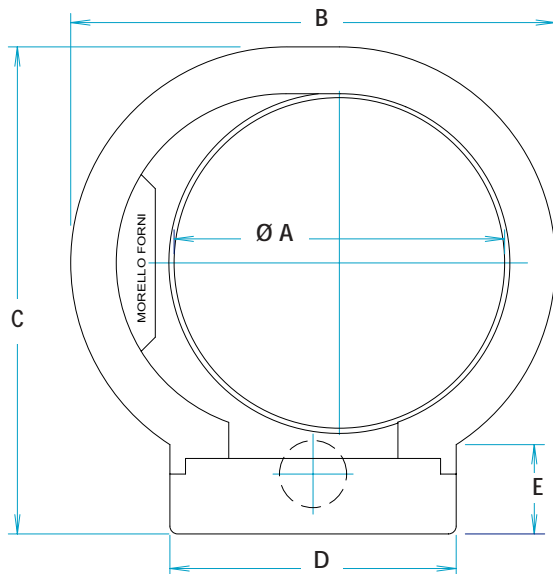
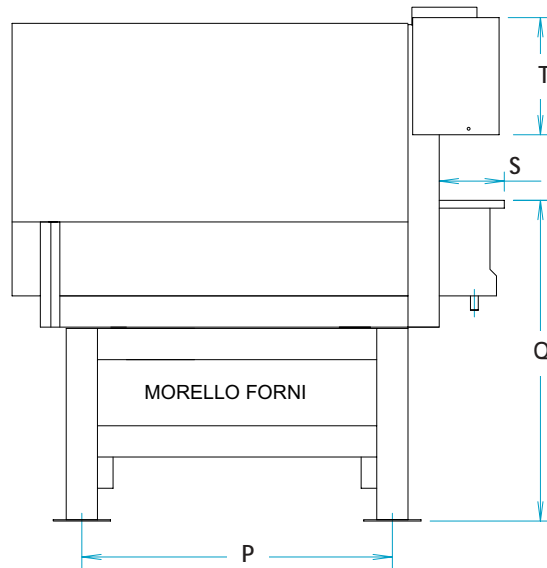
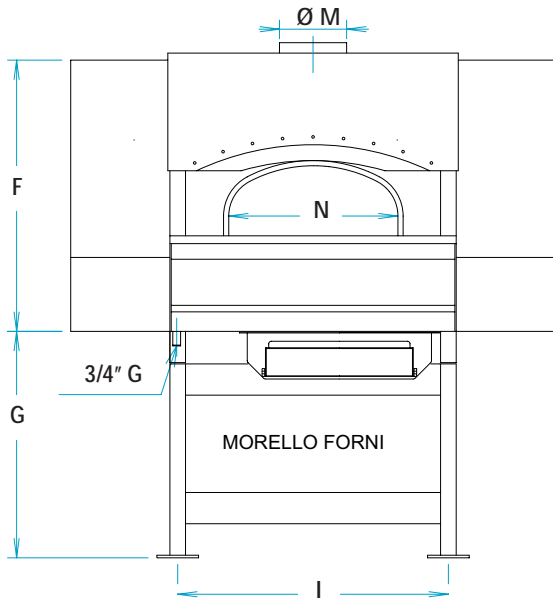

Forno Oven Mod.	Peso Weight (Kg)	Potenzialità Gas Total Gas potential	Consumo Consumption		Attacchi Gas Gas/fittings
			Metano/Methane (mc/h)	G.P.L./L.P.G. (Kg/h)	
FGR110	14000	28 kW	2,9	2,1	3/4" G
FGR130	1650	36 kW	3,8	2,7	3/4" G
FGR150	2150	43 kW	5	3,3	3/4" G

Ref./ Mod.	Capacità pizze Ø 30 cm. Capacity pizzas Ø 30 cm.	Produzione oraria Productivity per hour
FGR110	7 pizze	120 pizze/h
FGR130	10 pizze	170 pizze/h
FGR150	14 pizze	240 pizze/h

Ref./ Mod.	ØA	B	C	D	E	F	G	I	Ø M	N	P	Q	S	T
FGR110	106	165	165	100	37	107	87	94	25	55	98	118	25	50
FGR130	126	185	187	110	37	107	87	104	30	65	118	118	25	50
FGR150	146	205	210	120	37	107	87	114	30	75	138	118	25	50

Misure in cm - Sizes in cm

Le caratteristiche e i dati riportati nel presente catalogo possono subire variazioni senza preavviso

**MORELLO FORNI s.a.s.**  
Via Rivarolo 61 N/G - 16161 Genova - Italy  
Tel. +39 010 7401194 • Fax +39 010 7492194  
e-mail: info@morelloforni.com  
www.morelloforni.com

